

NANYANG PRIMARY SCHOOL

PRIMARY 6 SCIENCE

MID-YEAR EXAMINATION
2021

BOOKLET A

Total duration for Booklets A and B: 1 h 45 min

Booklet A consists of 19 printed pages including this cover page.

Section A: Multiple Choice Questions [56 marks]

For each question from 1 to 28, four options are given. One of them is the correct answer. Indicate your choice in this booklet and shade the correct oval (1, 2, 3 or 4) on the Optical Answer Sheet provided.

1. Diana wanted to investigate the conditions needed for a plant to photosynthesise. She placed plant X in a dark cupboard for two days to destarch it completely. After that, she wrapped up 4 leaves, A, B, C and D, in clear plastic bags containing different substances as shown in the diagram below.

Then she placed plant X under the sun for a few hours.

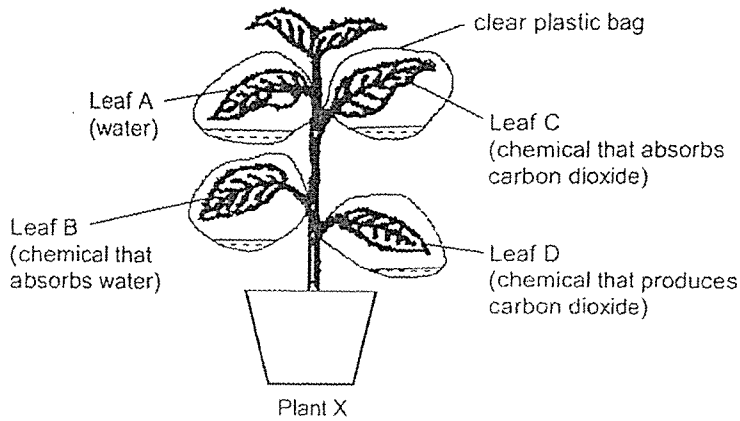

Diana then removed leaves A, B, C and D and tested them for starch.

Based on the conditions in which the leaves were placed, which one of the following is likely to be the results that she obtained?

Presence of Starch in Leaf				
	A	B	C	D
(1)	absent	present	present	present
(2)	present	absent	present	absent
(3)	present	present	absent	present
(4)	present	absent	absent	present

The diagram below shows a habitat.



4. Based on the diagram above, which of the following is correct?
- (1) The group of kangaroos form five populations.
 - (2) The rabbit and the bird form two communities.
 - (3) There are only animal populations in the habitat.
 - (4) There are different populations of plants and animals in the habitat.
5. Which of the following are examples of organisms that break down dead matter into simpler substances?
- A Ants
 - B Fungi
 - C Bacteria
 - D Earthworm
- (1) A and B only
 - (2) B and C only
 - (3) C and D only
 - (4) A, C and D only

6. The graph below shows how the number of fishes in a pond community changed over a period of 6 months. The fishes in the pond feed on the water plants.

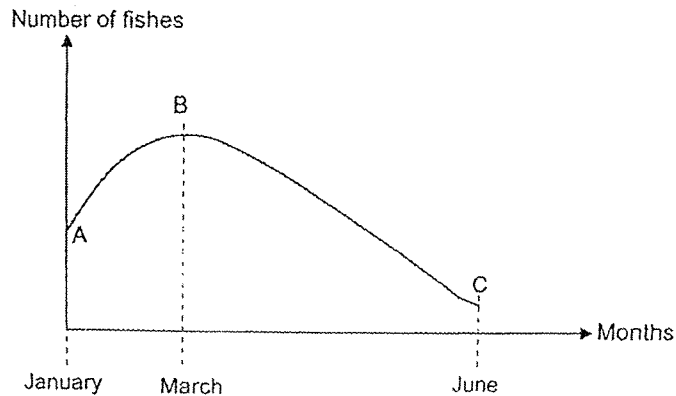

What are the likely reasons for the change in the number of fishes in the pond?

- A From A to B, the birth rate of fishes was equal to its death rate.
- B From A to B, the number of animals feeding on the fishes increased.
- C From B to C, water plants were removed from the pond.
- D From B to C, several organism X were added and they competed for food with the fishes.

- (1) A and B only
- (2) A and D only
- (3) B and C only
- (4) C and D only

7. Study the food web below.

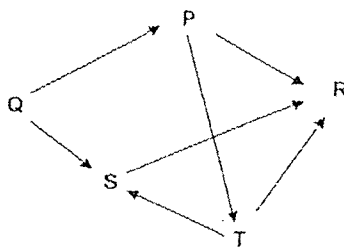

Which organisms are both a prey and a predator?

- (1) P and S only
- (2) Q and R only
- (3) S and T only
- (4) P, S and T only

8. The food chain below shows the relationship between four organisms in a community.

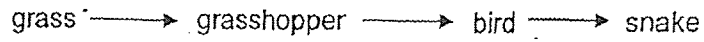

Based on the food chain above, which one of following graphs shows the change in population of grasshoppers and birds after the snakes were removed from the community?

(1)

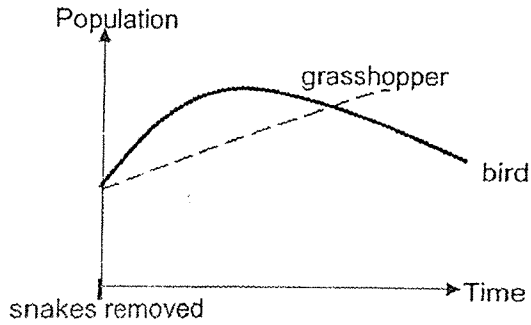

(2)

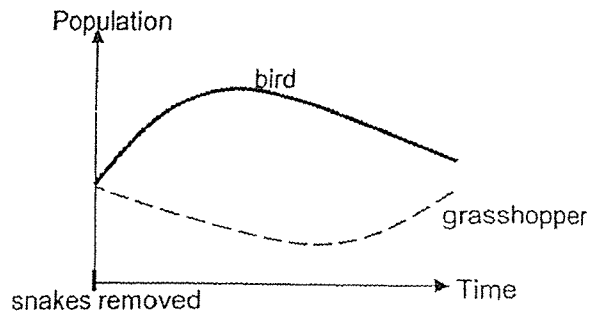

(3)

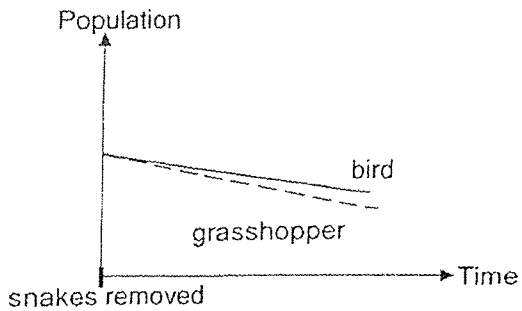

(4)

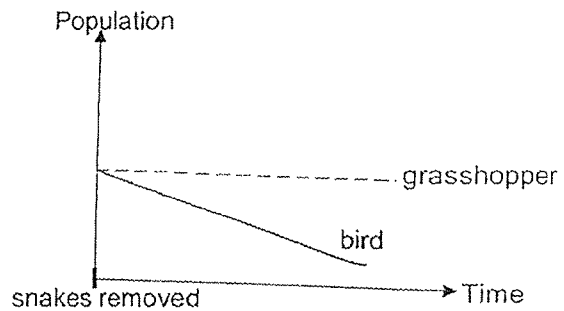

9. Study the food web below.

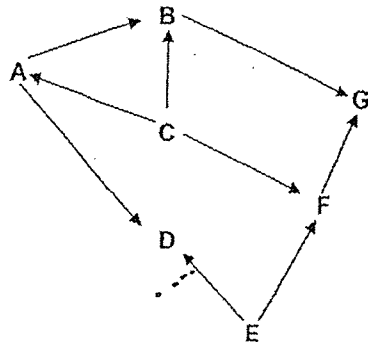

Which of the following correctly classifies the producers and plant-and-animal-eaters in the food web?

	Producers	Plant-and-animal-eaters
(1)	A and G only	C and D only
(2)	A and G only	D and F only
(3)	C and E only	A and F only
(4)	C and E only	B and D only

10. The following statements were made by some pupils.

- Julia: A food chain must start with a plant-eater.
 Taylor: The arrows in the food chain show the transfer of energy.
 Shawn: A food chain shows the relationship between producers and consumers.
 Eugene: At each position in the food chain, all the energy is used up for life processes.

Which pupils had made an incorrect statement?

- (1) Julia and Taylor only (2) Julia and Eugene only
 (3) Taylor and Shawn only (4) Shawn and Eugene only

13. Food-carrying tubes were removed from the stems of plants A and B as shown below. The plants were then left under the sun and watered every day. Their growth was observed over a month.

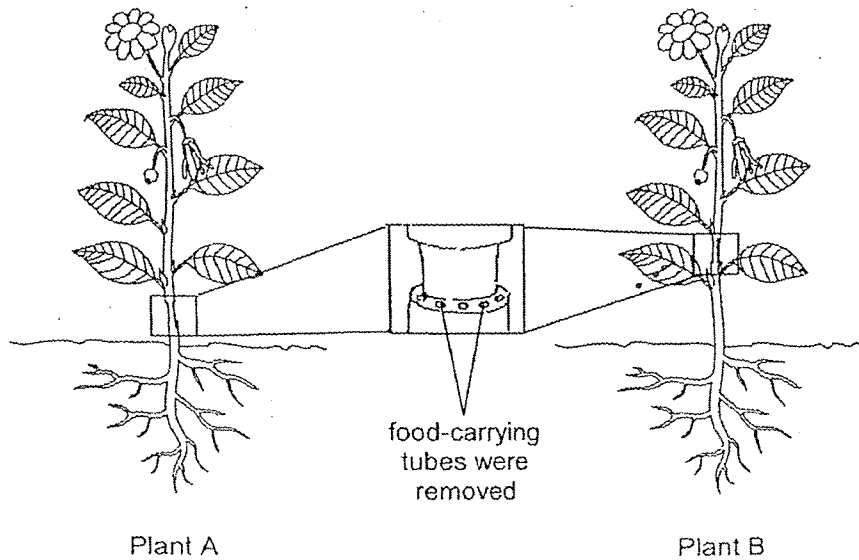

Which of the following correctly explains the possible observations that could have been made about plants A and B after a month?

	Plant A	Plant B	Explanation
(1)	died	survived	Only the roots of plant B were able to obtain food.
(2)	survived	died	Only the roots of plant A were able to obtain food.
(3)	survived	survived	The roots of both plants were able to obtain food.
(4)	died	died	The roots of both plants were not able to obtain food.

14. Which of the following shows the correct comparison of gases that we breathe in and out?

	Breathe in	Breathe out
(1)	less oxygen	more oxygen
(2)	more nitrogen	less nitrogen
(3)	more water vapour	less water vapour
(4)	less carbon dioxide	more carbon dioxide

The table below shows parts of the digestive system and their functions.

A tick (✓) indicates the presence of the function stated.

	Parts of the digestive system		
	A	B	C
Chewing takes place			✓
Absorbs water from undigested food	✓		
Breaks food down into simple substances		✓	✓

Which of the following correctly identifies parts A, B and C?

	A	B	C
(1)	small intestine	stomach	mouth
(2)	small intestine	stomach	gullet
(3)	large intestine	small intestine	mouth
(4)	large intestine	small intestine	gullet

Study the chart below.

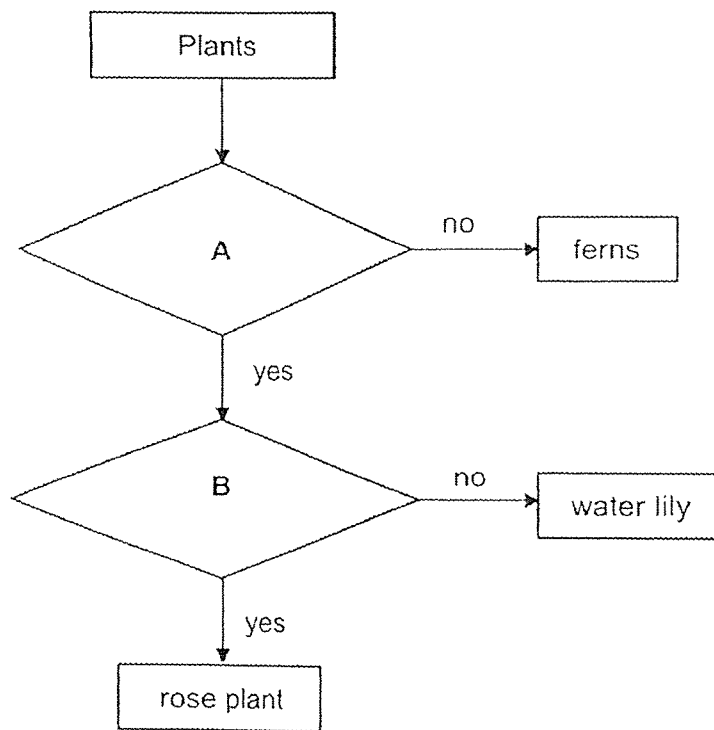

Which of the following correctly represent questions A and B?

	A	B
(1)	Does it bear fruits?	Does it grow on land?
(2)	Does it bear fruits?	Does it grow on water?
(3)	Does it makes its own food?	Does it grow on land?
(4)	Does it makes its own food?	Does it grow on water?

17. The table below shows the state of three substances P, Q and R at different temperatures.

Substance	State of Substance		
	20°C	40°C	60°C
P	solid	solid	solid
Q	liquid	liquid	gas
R	solid	solid	liquid

Based on the information above, which of the following statements are true?

- A Substance Q has the lowest boiling point.
- B Substance P has the highest melting point.
- C Substance R has a lower freezing point than substance P.

- (1) A and B only
- (2) A and C only
- (3) B and C only
- (4) A, B and C

18. Sarina left a cup of water on the table as shown in the diagram below.

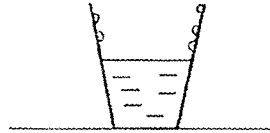

Which one of the following graphs shows the change in temperature of the cup of water over time?

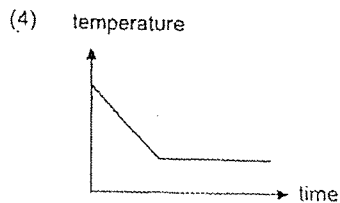
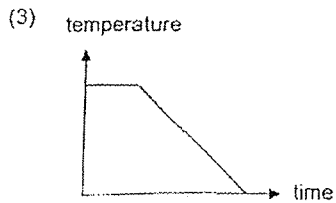
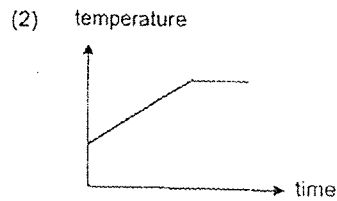
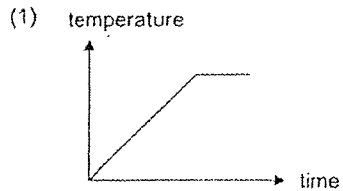

19. Study the classification chart below.

Useful form of energy X	Non-useful form of energy X
Group A	Group B

In which of the following are electrical appliances classified correctly into Groups A and B based on the form of energy X?

	Group A	Group B	Energy X
(1)	oven	water heater	heat energy
(2)	computer	hairdryer	kinetic energy
(3)	refrigerator	fan	light energy
(4)	radio	lamp	sound energy

20. The diagram below shows a solar-powered toy. The flower moves from side to side while the leaves move up and down.

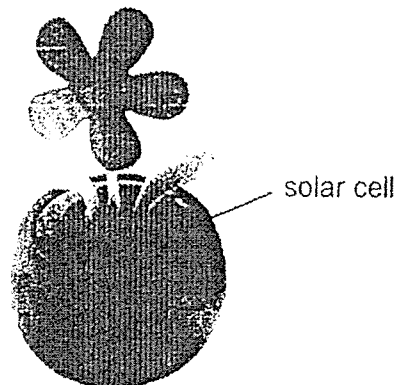

What energy conversion takes place in the toy?

- (1) Electrical energy → light energy → kinetic energy
- (2) Light energy → potential energy → kinetic energy
- (3) Light energy → electrical energy → kinetic energy
- (4) Potential energy → light energy → kinetic energy

21. The diagram below shows part of a roller coaster ride with positions X, Y and Z.

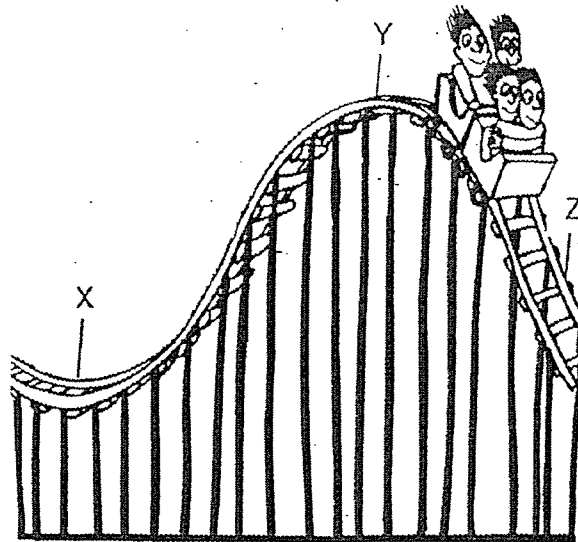

Which of the following correctly state the energy forms and conversions when the roller coaster moves along the different positions?

- A From X to Y, potential energy is converted to kinetic energy.
- B From Y to Z, potential energy is converted to kinetic energy.
- C The roller coaster has more kinetic energy at Y than at Z.
- D The roller coaster has more potential energy at X than at Z.

- (1) A and C only
- (2) A and D only
- (3) B and C only
- (4) B and D only

22. The diagram below shows the path a ball took from positions X, Y and Z after it was kicked.

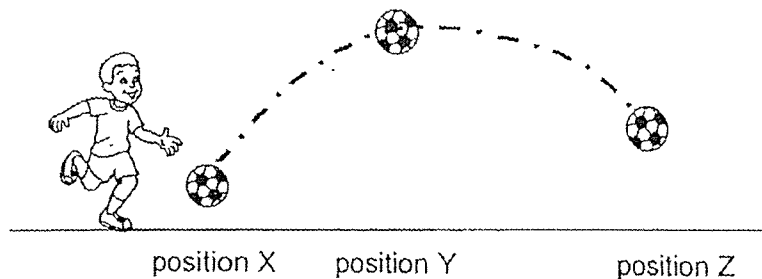

Which of the following describes the energy possessed by the ball at the different positions?

- A The ball possessed no kinetic energy at Y.
- B The ball had more kinetic energy at Z than at Y.
- C From X to Y, kinetic energy of the ball increased.
- D From Y to Z, potential energy of the ball decreased.

- (1) A and C only
- (2) B and D only
- (3) A, B and D only
- (4) B, C and D

Hui En set up an experiment as shown in the diagram below.

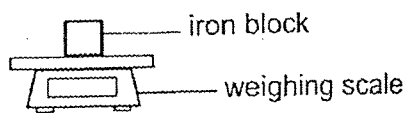

Figure 1

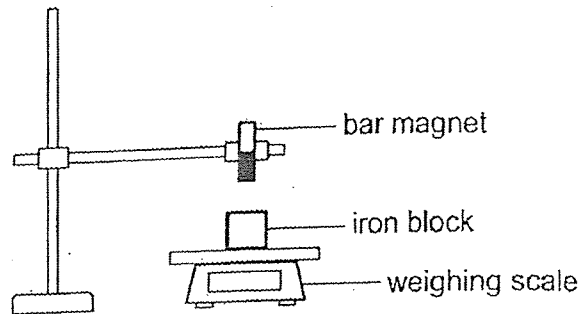

Figure 2

She placed an iron block on the weighing scale and recorded the reading.

A bar magnet was then brought near the iron block and the new reading was recorded. She repeated the steps with a plastic block and button magnet.

Her results are shown in the table below.

Object on weighing scale	Reading on weighing scale (g)	
	Figure 1	Figure 2
iron block	12.0	11.0
plastic block	12.0	12.0
button magnet	12.0	14.5

Based only on Hui En's observations, which of the following conclusions can be made?

- A The bar magnet attracted the iron block.
- B The bar magnet attracted the button magnet.
- C The bar magnet has no effect on the plastic block.

- (1) A only
- (2) A and C only
- (3) B and C only
- (4) A, B and C

Karl prepared set-up 1. He then placed object B under object A as shown i below. The original length of the spring is 2 cm.

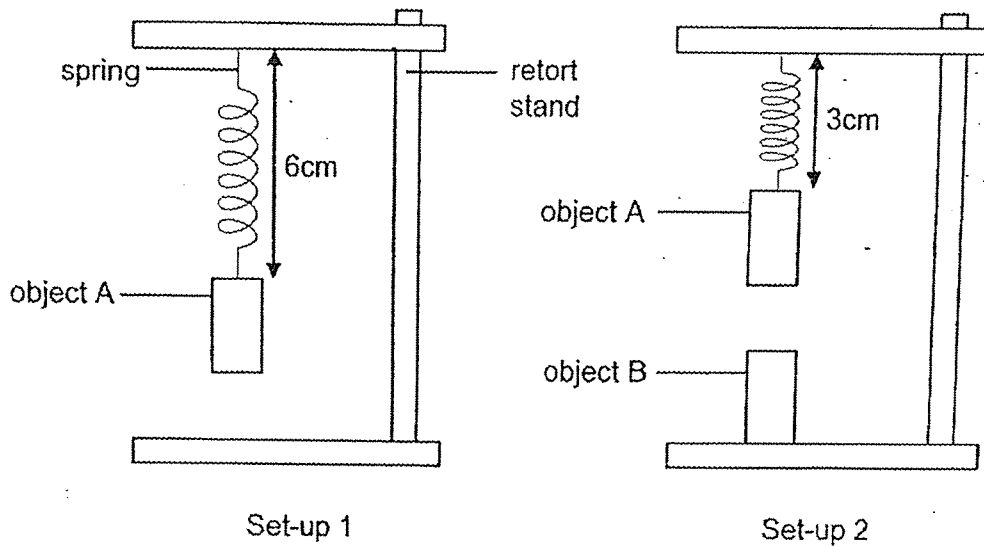

What are the forces acting on object A in set-up 2?

- A Magnetic force
- B Gravitational force
- C Elastic spring force

- (1) A only
- (2) A and B only
- (3) B and C only
- (4) A, B and C

25. Jolyn set up an experiment in a dark room. She shone a torch on a football stuck to the ground at point T as shown in the diagram below. A shadow was formed on the screen.

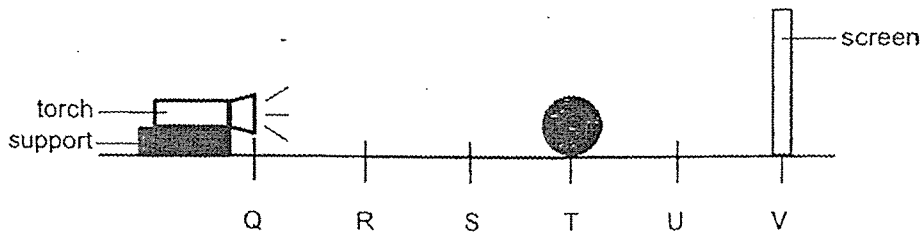

She then placed the torch and the screen at different positions. Which of the following combinations would form the **smallest** shadow on the screen?

	Position of torch	Position of screen
(1)	Q	V
(2)	R	U
(3)	S	V
(4)	Q	U

Afi set up the following experiment to find out more about materials K, L, M and N. The materials were cut into rectangular sheets.

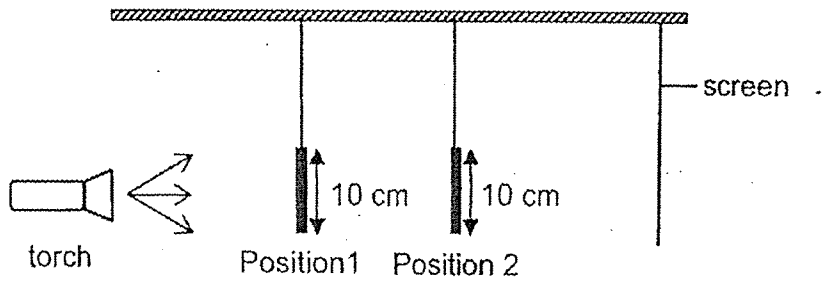

He placed two materials at positions 1 and 2 and observed the shadow formed on the screen. The table below shows his findings.

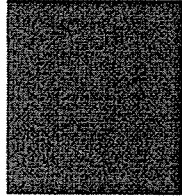
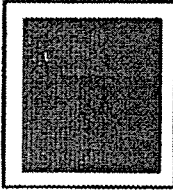
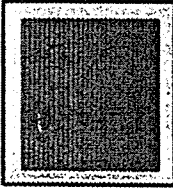
Position 1	Position 2	Shadow observed on the screen
K	L	 screen
N	K	 screen
L	M	 screen

Based on his observations, which of the following is correct?

	Allows most light to pass through	Allows some light to pass through	Does not allow light to pass through
(1)	M	K, N	L
(2)	M, N	L	K
(3)	N	L	K, M
(4)	L	M	K, N

27. Sophia placed equal amounts of water of the same temperature into two containers to boil. The containers are of the same size but are made of different materials, X and Y, respectively. The graph below shows the time taken for the water in each container to boil.

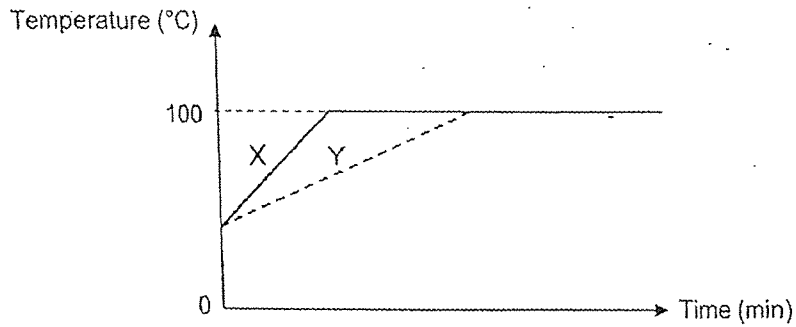

Sophia then used the materials to make a container to keep some cold water.

Which of the following set-ups will keep the water cold for the longest time?

(1)

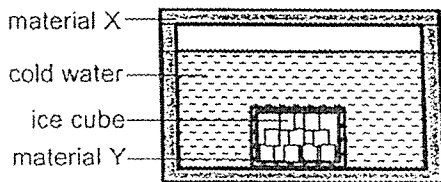

(2)

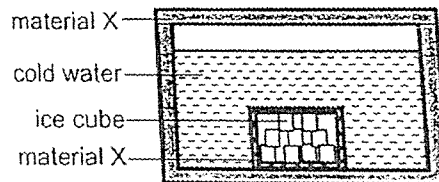

(3)

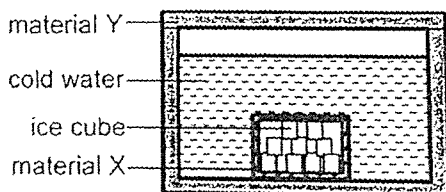

(4)

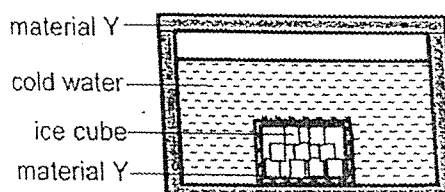

28. When railway tracks are designed, gaps are left between them to allow for expansion of the tracks so that they would not be damaged. Each section of the railway track, part X, is of the same length.

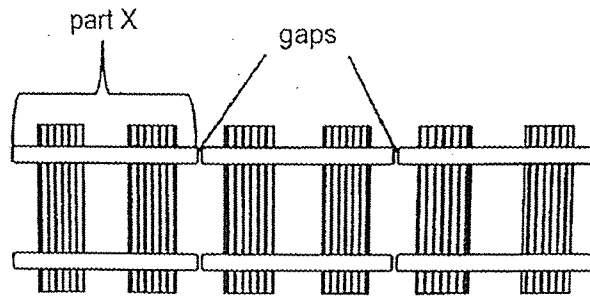

Top view of the railway tracks

Which of the following information would be most useful to a person building the railway tracks to ensure that there is a wide enough gap between part X?

- (1) Smallest length of part X on the coldest day
- (2) Greatest length of part X on the coldest day
- (3) Smallest length of part X on the hottest day
- (4) Greatest length of part X on the hottest day

END OF BOOKLET A

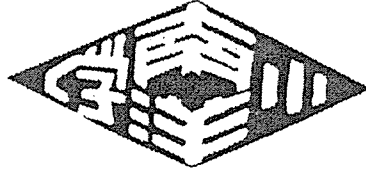

NANYANG PRIMARY SCHOOL
PRIMARY 6 SCIENCE
MID-YEAR EXAMINATION
2021

BOOKLET B

Total duration for Booklets A and B: 1 h 45 min

Booklet B consists of 17 printed pages including this cover page.

Section B: Open-Ended Questions [44 marks]

Write your answers to Questions 29 to 40 in the spaces provided.

29. The diagram below shows community Z.

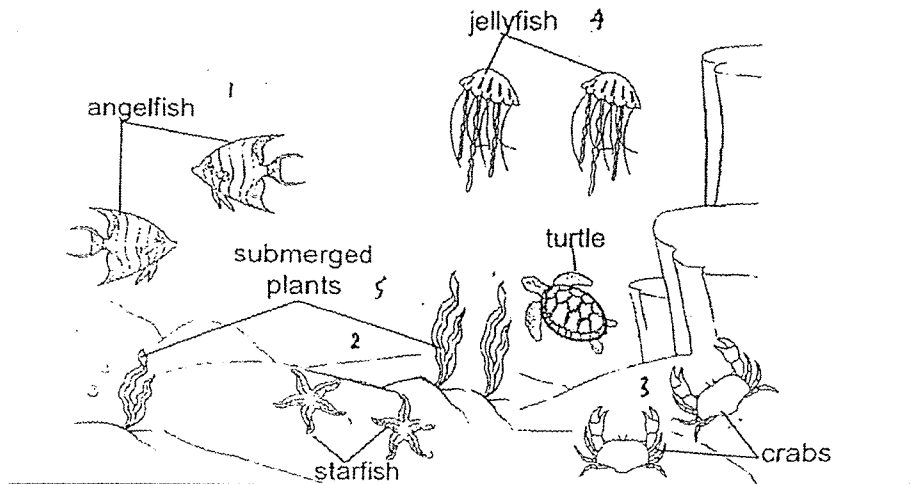

(a) What is a community? [1]

(b) Based on the picture above, state the number of population(s) in community Z. [1]

Organism S lives in the shallow area of the ocean floor in community Z.

The following observations were made about organisms R and S.

- R lives on S.
- R is of a similar colour as the ocean floor.

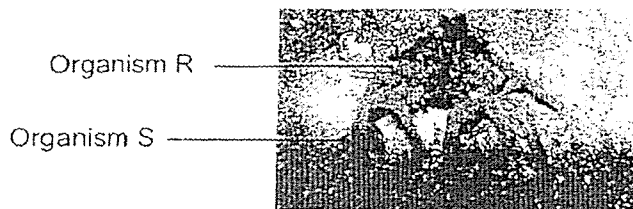

(c) Based on the information above, how does Organism S benefit from its interaction with organism R? [1]

30.

Skyler went to the aquarium. He saw a diagram that shows the food web of the different organisms in a tank as shown below.

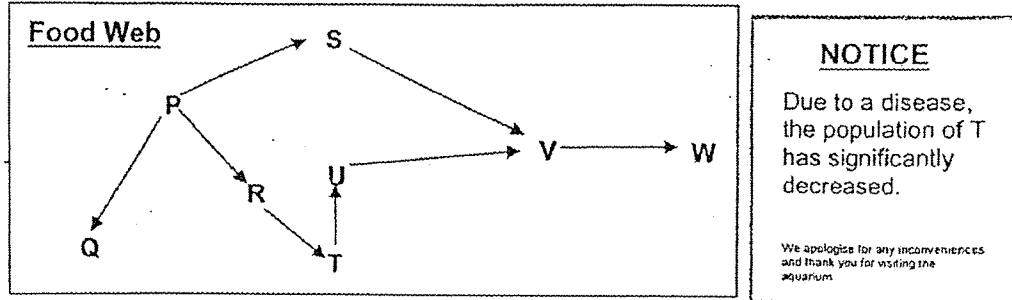

(a) He saw a notice at the corner stating that due to a disease, the population of T had decreased significantly. [2]

(i) Identify the organism(s) that would be directly affected when T decreased significantly.

(ii) Explain how the organism(s) in (i) would be affected.

Skyler then went home and recorded the different observations about Organisms A, B, C, D and E in his aquarium.

- A and B are plants.
- E feeds on B.
- C feeds on A and E.
- C and E are eaten by D.

(b) Based on the information above, complete the food web below by filling in the boxes with organism A, B, C, D and E. [2]

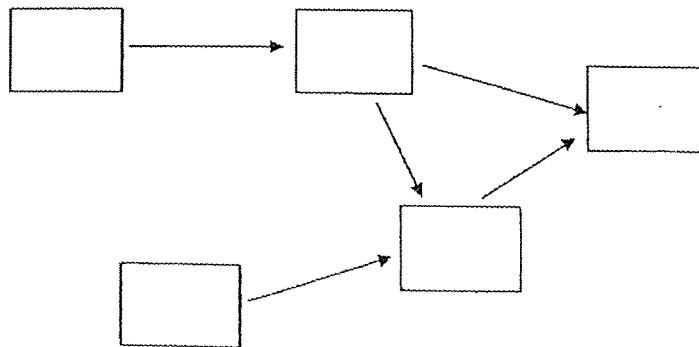

4

31. Stephanie placed different amounts of substance X on paper flowers of similar size and colour as shown below.

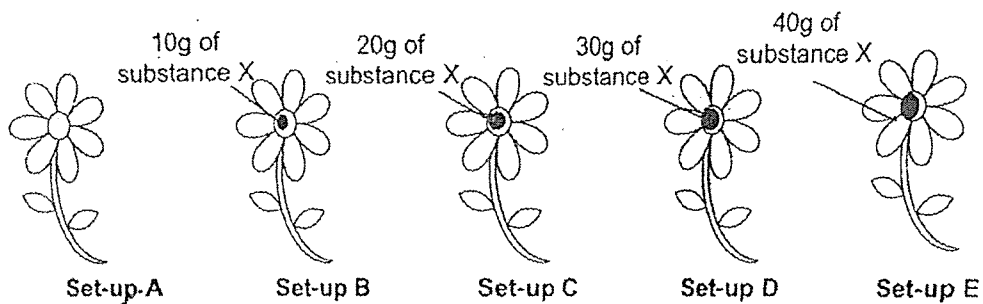

She then placed the flowers in a room filled with butterflies. She counted the number of butterflies that were attracted to the paper flowers as shown in the table below.

Set-up	Amount of substance X added onto the paper flower (g)	Number of butterflies attracted to the paper flower
A	0	0
B	10	8
C	20	8
D	30	7
E	40	8

- (a) Set-up A is a control set-up. What is the purpose of set-up A? [1]

- (b) Based on her results, what can Stephanie conclude about the effects of different amounts of substance X? [1]

(Continue from Question 31)

The diagram below shows a butterfly obtaining nectar from flower A.

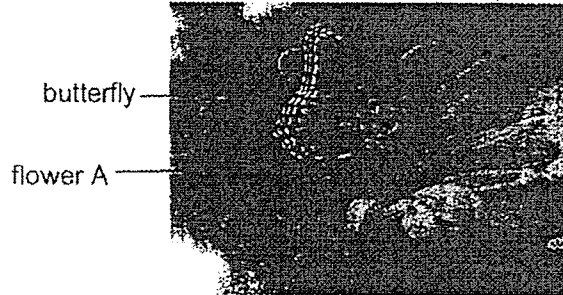

- (c) Based on the diagram above, explain how flower A benefits from its interaction with the butterfly. [1]

After some time, a fruit developed from flower A. The fruit has many seeds.

- (d) Explain why having more seeds is an advantage for flower A. [1]

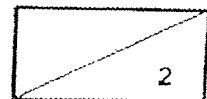

32. (a) Fill in the blanks with 'heart' or 'lungs' in each of the boxes below. Each word can only be used once. [1]

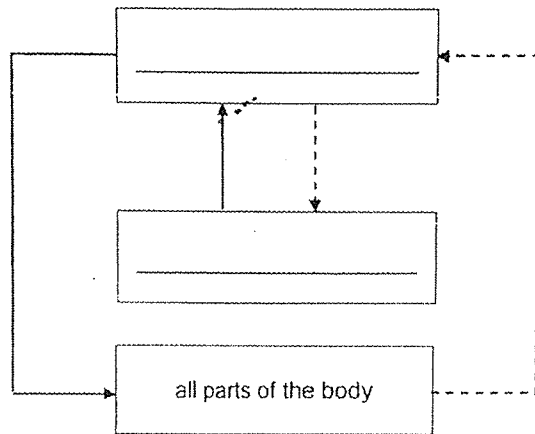
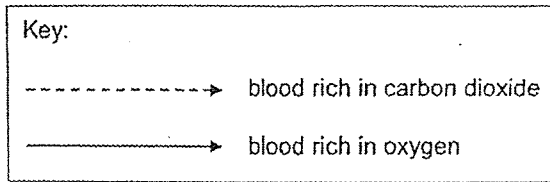

The diagram below shows tubes X and Y in the stem of a plant, which transport substances within the plant.

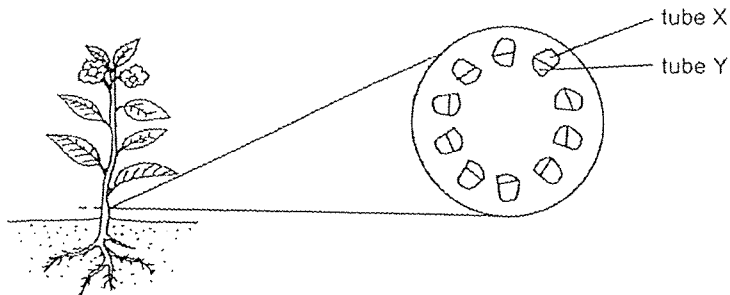

- (b) In the table below, ^{list} compare the substances transported in tubes X and Y of the plant and in the blood flowing through blood vessels in the human body. [2]

Tubes X and Y	Blood in blood vessels
(i) _____	(iii) _____
(ii) _____	(iv) _____

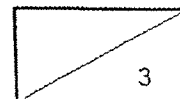

33. Willa ran up a hill. Once she reached the top of the hill, she started walking down. The graph below shows the changes in Willa's breathing rate before, during and after running.

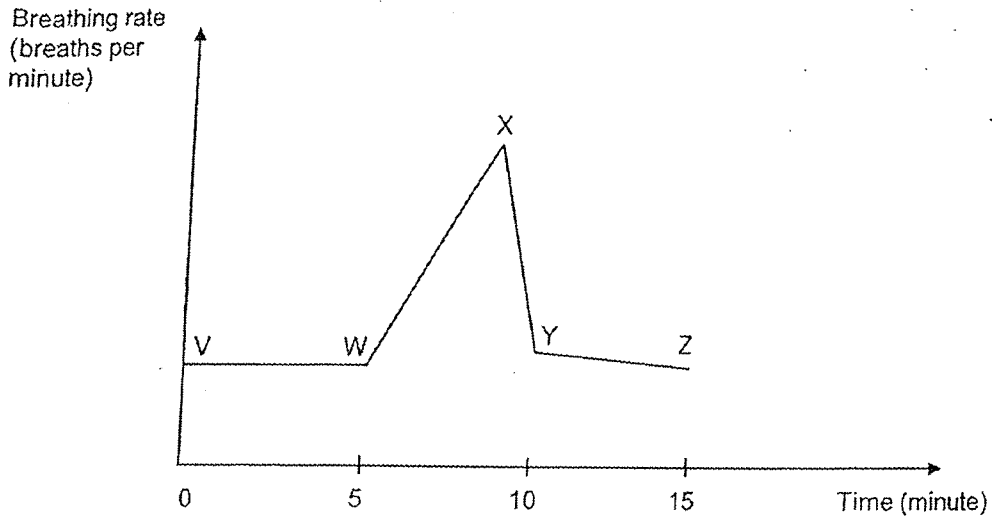

- (a) At which point, V, W, X, Y or Z, did Willa stop running? [1]

Point _____

Willa observed that when she exercised, both her breathing rate and heart rate increased.

- (b) Why did both her breathing rate and heart rate increase when she exercised? Explain your answer. [2]

(i) the increase in breathing rate

(ii) the increase in heart rate

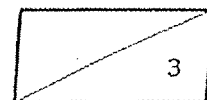

34. Anthony observed four cells, A, B, C and D, under the microscope. He recorded his observations in the table below. A tick (✓) indicates the presence of the part of a cell.

Cell Part	Cell A	Cell B	Cell C	Cell D
Cell wall	✓		✓	
Nucleus	✓		✓	✓
Chloroplast			✓	
Cell membrane	✓	✓	✓	✓

(a) Based on his observations, which of the above cell(s) is/are likely to be a plant cell? Give a reason for your answer. [1]

(b) (i) State another common cell part between cells A, B, C and D that is not stated in the table. [1]

(ii) Describe the function of the cell part in (i).

Anthony then observed the cells over a period of time. He recorded his observations in the graph below.

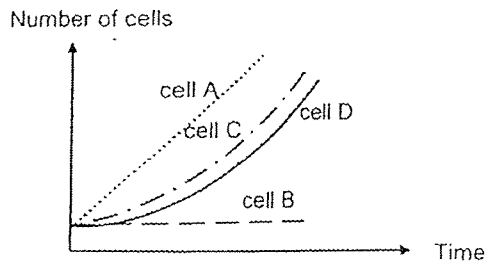

(c) Based on the table and the graph above, what can Anthony conclude about the function of the nucleus? [1]

35. The graph below shows the amount of digested food in various parts of the digestive system after a girl had a meal.

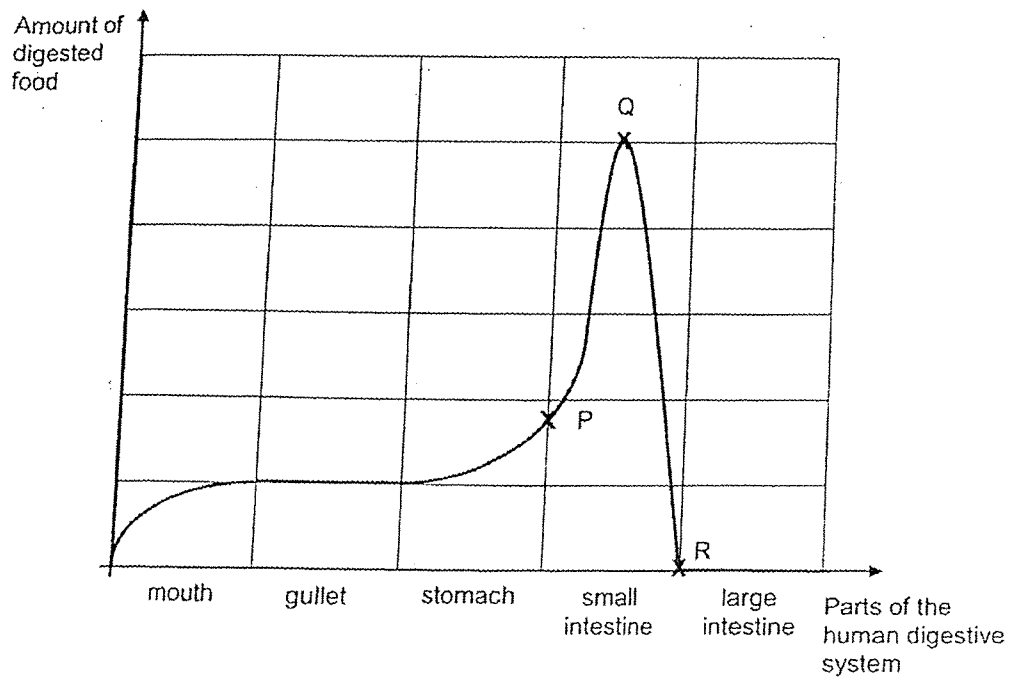

- (a) Which part(s) of the digestive system produce(s) digestive juices? [1]

- (b) Describe and explain the changes in the amount of digested food in the small intestine, between points P and R. [2]

- (i) From point P to point Q

- (ii) From point Q to point R

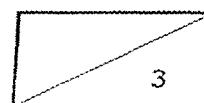

Tina hung four balls of the same size, P, Q, R and S, from a rod over a sand tray as shown in the diagram below. The mass of balls P and R was 100 g each and the mass of balls Q and S was 200 g each.

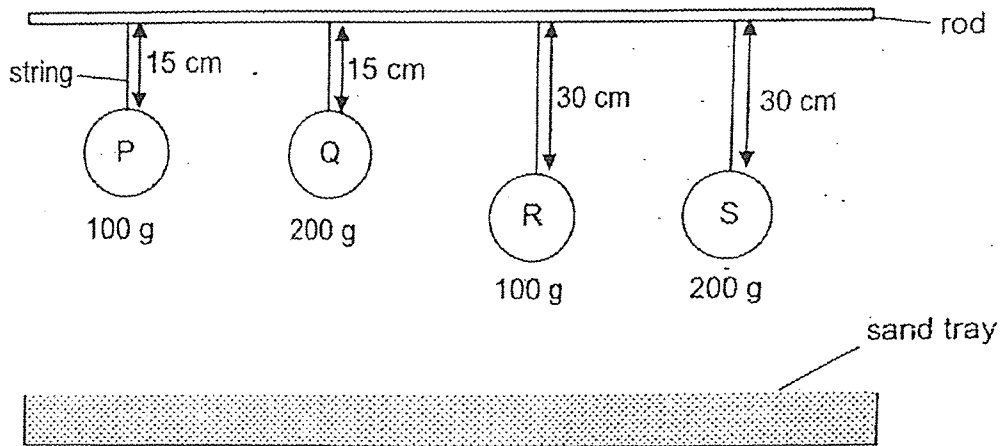

When the strings were cut, the balls dropped and landed in the tray of sand.

(a) What main energy changes took place in the balls when the strings were cut? [1]

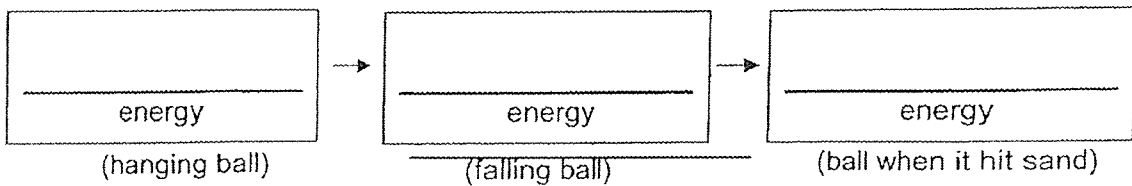

(b) Which ball would make the deepest dent in the sand? Explain your answer in terms of energy conversion. [2]

Diagrams 1, 2 and 3 below show different ways of measuring the depth of the dent.

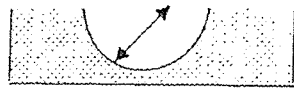

Diagram 1

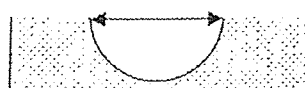

Diagram 2

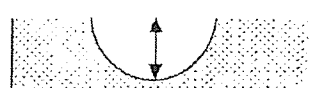
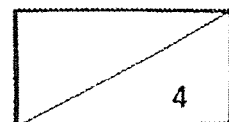

Diagram 3

(c) Which diagram shows the correct distance that Tina should measure for the experiment? [1]

Diagram _____



(Continue from Question 36)

- (d) Tina wanted to compare only the results for balls R and S. What was the aim of her experiment? [1]

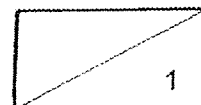

37. Thomas conducted an experiment using the set-up shown below.

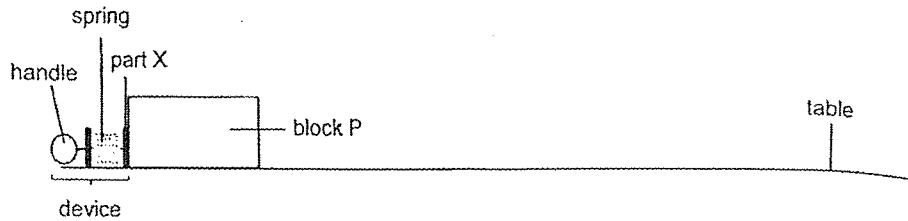

When the handle was pulled, part X was pulled back to compress the 8-cm spring to 5cm. When the handle is released, part X hit block P and pushed it forward. Thomas then measured the distance the block travelled across the table after the handle was released.

- (a) In the diagram below, draw and label two forces acting on block P as it travelled across the table. [1]

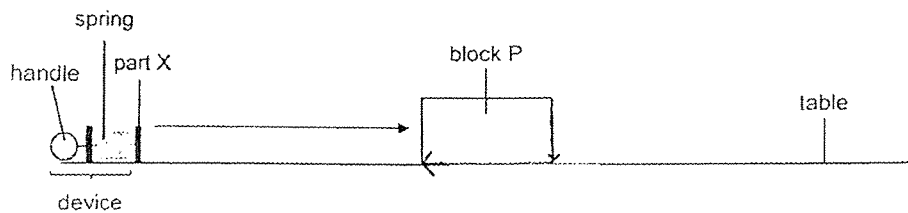

Thomas then repeated the experiment with blocks Q and R. He recorded the information for his experiment are shown in the table below.

Block	Surface area of block in contact with the table (cm ²)	Mass of the block (g)	Distance travelled by the block (cm)
P	100	100	12
Q	100	200	7
R	120	100	12

- (b) (i) Based only on the information given above, identify the factor that affected the distance travelled by the block across the table. [1]

- (ii) Explain your answer in (i). [1]

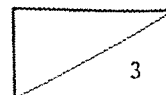

(Continue from Question 37)

The spring in the device broke. Thomas decided to replace the spring. He was given two 8-cm springs, A and B, that could be used in the device. He placed two identical 3-kg masses on the springs as shown below.

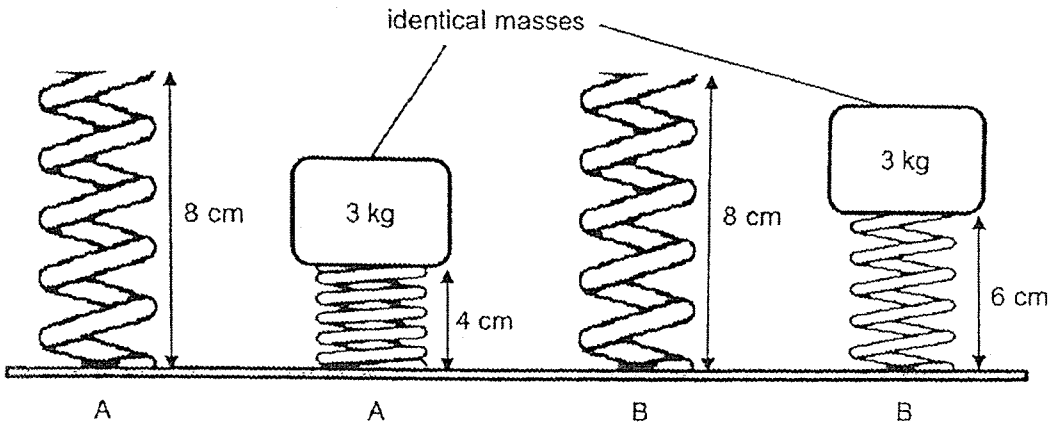

- (c) Based on the above observations, which spring should Thomas use to enable the blocks to travel a greater distance across the table? Explain your answer in terms of forces. [2]

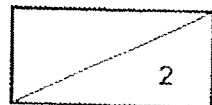

38. Jia Quan set up an experiment in a dark room as shown below. He wanted to find out how much light from the torch was detected when different cloth samples were placed in the material holder.

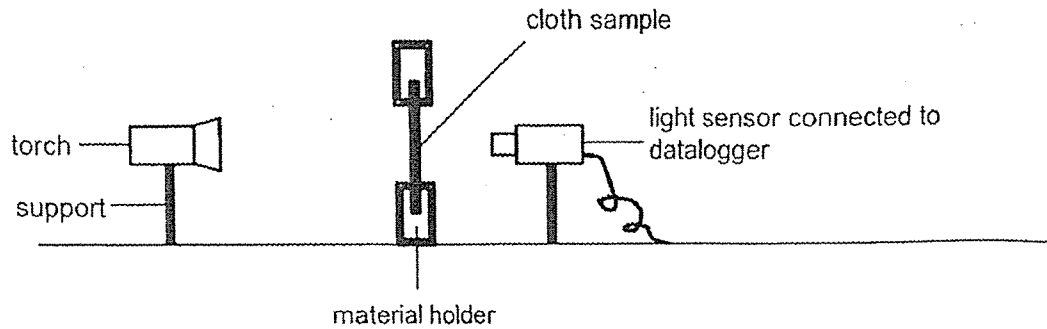

He recorded the amount of light detected by the light sensor for each cloth sample P, Q, R and S. The positions of the torch, material holder and light sensor were kept constant during the experiment. He recorded his results in the table below.

Cloth sample	Amount of light detected (units)
P	350
Q	150
R	200
S	50

- (a) Why did Jia Quan conduct the experiment in a dark room? [1]

- (b) Jia Quan wanted to make a curtain that will keep his room dark during the daytime. Which cloth sample should he choose for his curtain? Explain your answer. [1]

- (c) State two other variables that will affect the amount of light detected by the light sensor in the set-up above. [2]

(i) _____

(ii) _____

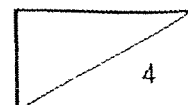

39. Kumar carried out an investigation. He poured 10ml of saltwater and left it uncovered on a table. After 2 hours, he noticed that the mug was empty except for some white substance left.

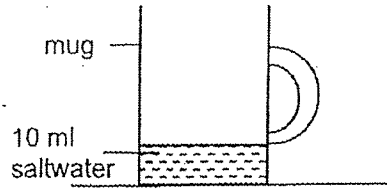

- (a) Explain why only the white substance was left after 2 hours. [1]

- (b) Suggest 2 ways Kumar can obtain the white substance faster using the same mug and 10 ml of the same type of saltwater. [2]

(i) _____

(ii) _____

40. Sharmini placed two identical flasks, A and B, into identical containers, A and B, respectively. The flasks were connected by a glass tube with an ink drop in the centre as shown in the diagram below.

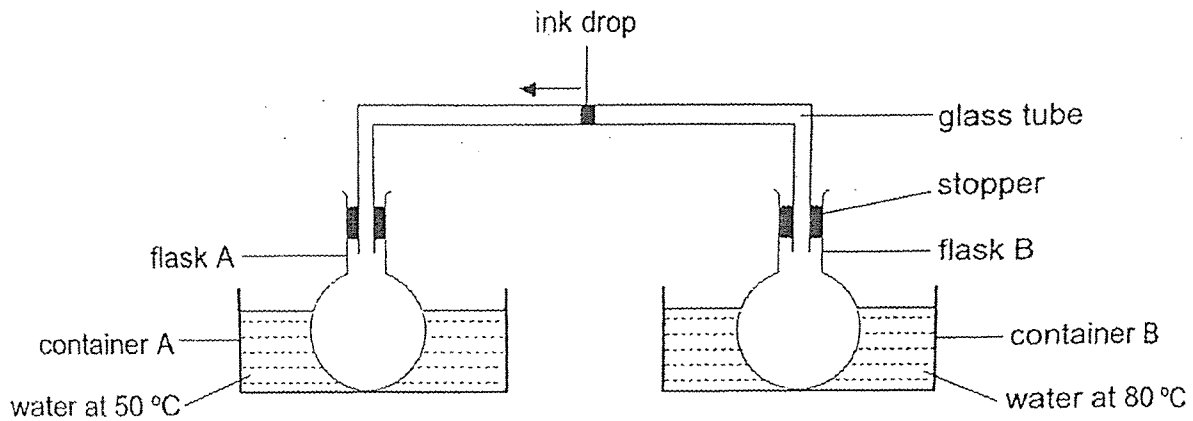

Sharmini then poured equal amounts of hot water into the two containers. The water in container A was 50 °C while the water in container B was 80 °C.

- (a) Explain why the ink drop moved from the centre of the glass tube towards flask A after some time. [1]

She then emptied containers A and B and allowed the apparatus in the set-up to cool to room temperature. She only poured water at 80 °C into both containers. After some time, Sharmini observed that the ink drop still moved from the centre of the glass tube towards flask A.

- (b) What could she have done to cause the observation? [1]

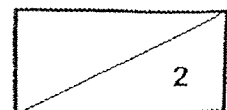

(Continue from Question 40)

Sharmini was given two waterproof materials, R and S. She decided to test the materials using the set-ups below. She wrapped flasks A and B with materials R and S respectively. She then poured equal amounts of water at 80 °C into the containers as shown below.

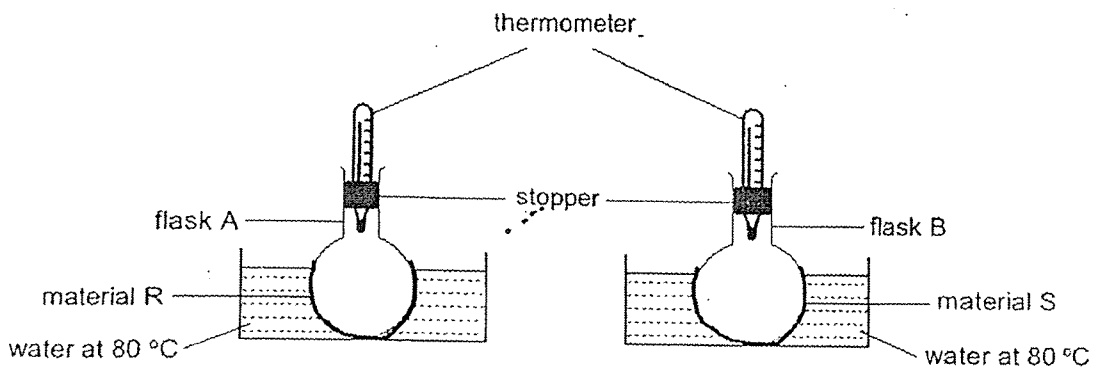

Using the thermometers in the set-ups, she measured the temperature of air in the flask after 30 minutes and recorded the results in the table as shown below.

Material	Temperature of air in the flask (°C)	
	At the start of the experiment	After 30 minutes
R	30	60
S	30	40

- (c) Based on her observation, which material, R or S, should Sharmini use to wrap her leftover pizza so that it would stay warm for a longer time? Explain your answer. [2]

~ END OF BOOKLET B ~

